

K3D160 ±50kN

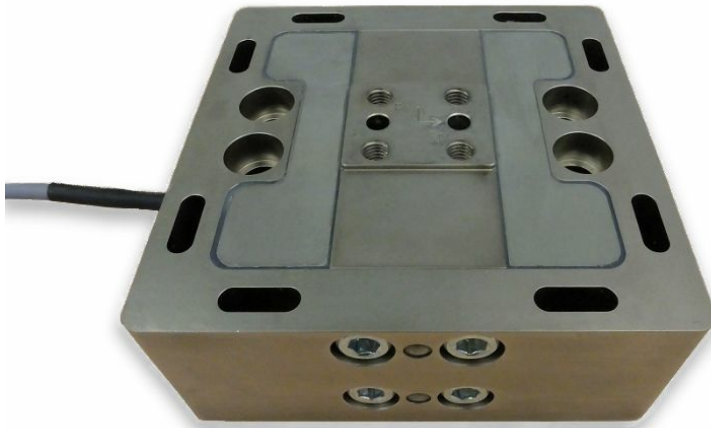

Description

The 3-axis sensor K3D160 is suitable for measuring force in three mutually perpendicular axes.

Force is applied from the 42mm x 50mm recess. A component can be installed on this surface with four M10 screws. The bottom of the sensor is fixed to the bottom with four M12 screws.

Application areas

Areas of application are, for example, force measurement during production processes, force control in handling machines, force measurement during assembly processes, three-dimensional load measurement, measurement of friction forces.

Dimensions

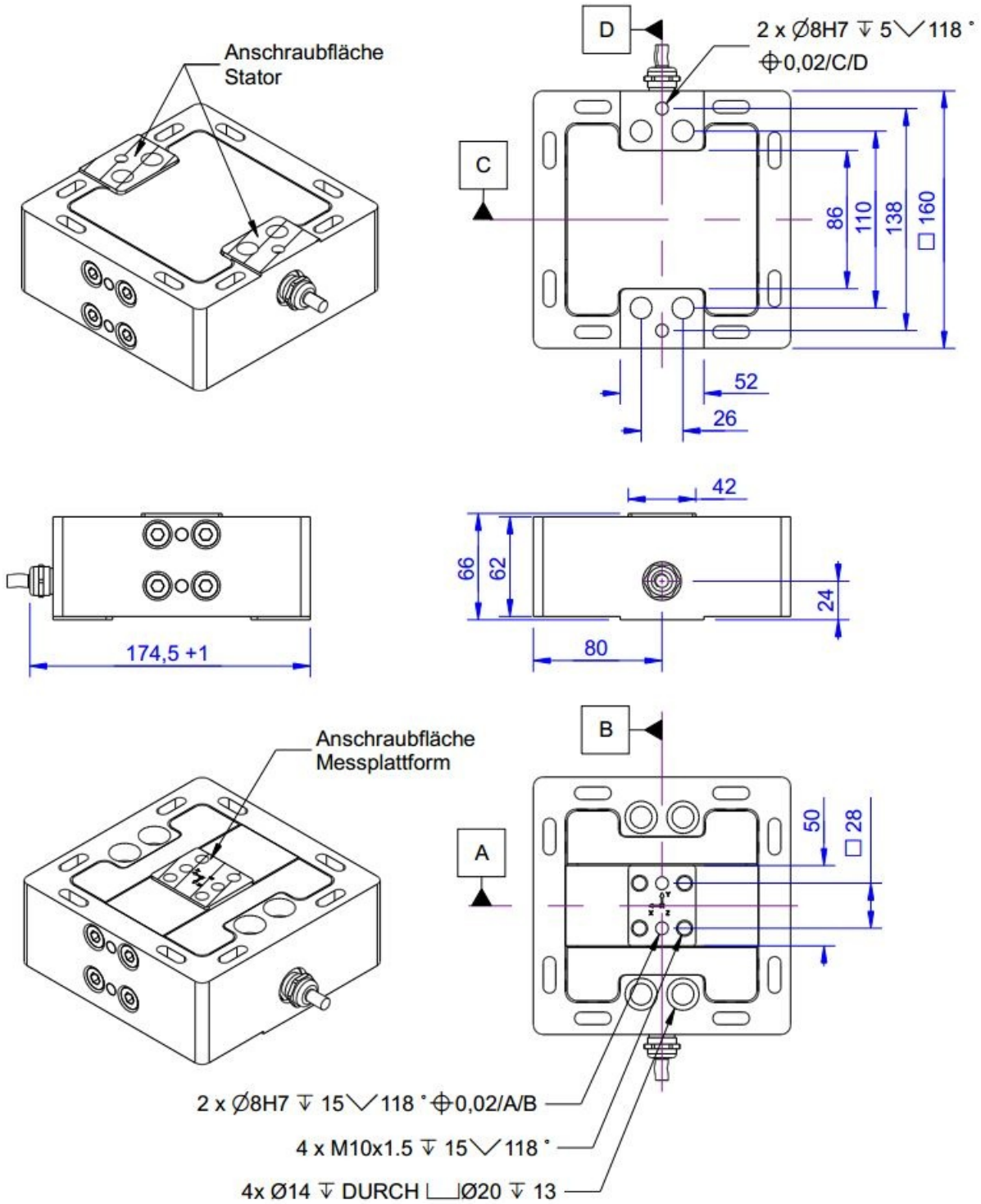

Technical Data

Force sensor

Type	3-axis force sensor
Force direction	Tension / Compression
Rated force Fx	50 kN
Rated force Fy	50 kN
Rated force Fz	50 kN
Force introduction	Inner thread
Dimension 1	4xM10
Sensor Fastening	Through bore
Dimension 2	4xØ14
Operating force	150 %FS
Rated displacement	0.08 mm
Material	Tool steel
Natural frequency	10 kHz
Height	66 mm
Length or Diameter	160 mm
Torque limit	2 kNm
Bending moment limit	2 kNm

Precision

Accuracy class	0,5%
Relative linearity error	0.4 %FS
Relative zero signal hysteresis	0.1 %FS
Temperature effect on zero signal	0.02 %FS/K
Temperature effect on characteristic value	0.01 %RD/K
Relative creep	0.1 %FS

Connection Data

Connection type	12 conductor open
Name of the connection	Unitronic FD CP (TP) Plus 6 x 2 x 0,14
Cable length	5 m

Eccentricity and Crosstalk

Allowed torque according of eccentric load	1000 Nm
Influence of eccentric load to FS	1 %FS / 500Nm
Crosstalk from x to y at rated load	2 %FS
Crosstalk from y to x at rated load	2 %FS
Crosstalk from z to x/y at rated load	2 %FS
Crosstalk from x/y to z at rated load	2

Temperature

Rated temperature range f	-10 ... 50 °C
Operating temperature range f	-10 ... 85 °C



Storage temperature range f	-10 ... 85 °C
Environmental protection	IP67

Electrical Data

Rated output x-axis	1 mV/V
Rated output y-axis	1 mV/V
Rated output z-axis	1 mV/V
Zero signal	0.05 mV/V
Rated range of excitation voltage f	2.5 ... 5 V
Operating range of excitation voltage f	1 ... 10 V
Input resistance x-axis	740 Ohm
Output resistance x-axis	700 Ohm
Input resistance y-axis	740 Ohm
Output resistance y-axis	700 Ohm
Input resistance z-axis	740 Ohm
Output resistance z-axis	700 Ohm
Insulation resistance	5 GOhm
Tolerance input resistance	10 Ohm
Tolerance output resistance	5 Ohm

Abbreviation : RD: „Reading“; FS: „Full Scale“;

1. The exact nominal sensitivity is indicated in the test report;





Pin Configuration

Channel	Symbol	Description	Wire colour	PIN
X-Axis	+Us	sensor supply	brown	2
	-Us	sensor supply	white	1
	+Ud	bridge output	green	3
	-Ud	bridge output	yellow	4
Y-Axis	+Us	sensor supply	pink	6
	-Us	sensor supply	grey	5
	+Ud	bridge output	blue	7
	-Ud	bridge output	red	8
Z-Axis	+Us	sensor supply	purple	10
	-Us	sensor supply	black	9
	+Ud	bridge output	grey / pink	11
	-Ud	bridge output	red / blue	12

Pressure load: positive output signal.

Shield- transparent.

accessories

Description	Description
 Calibration Certificate kn/200/5/K3D	Factory calibration certificate for force from 21 kN to 200 kN in accordance with DIN EN ISO / IEC 17025 for test materials monitoring according to DIN ISO 9001: 2008 with 5 load levels and 3 series of measurements.
 GSV-8DS	8-channel amplifier with USB port, analog output, UART interface. Other versions GSV-8AS CAN with Canbus and GSV-8AS EC with EtherCAT fieldbus.
 GSV-1A4 SubD37/2	4-channel strain gauge measuring amplifier for sensors with strain gauges. Adaptation of the sensor via Sub-D-37 connector . Output $\pm 10V$ and 4 ... 20mA via 15-pin SUB-D (female); Input sensitivity 2mV/V;
 GSV-4USB SubD37	4-channel strain measurement amplifier with USB port with configurable input for strain gauges, temperature sensors, active sensors, displacement sensors and other sensors. Sensor connection via 1 piece Sub D37 connector