

GSV-1A4 SubD37/2 2.5kHz



Highlights

- Input sensitivity: 2mV/V;
- 4mV/V, 2 mV/V, 1mV/V, 0.5mV/V configurable via jumpers
- Output signals $\pm 10V$ AND 12mA+8mA on 15 pin Sub-D
- Integrated half and quarter bridge completion for 350 ohm strain gauge
- Tare function individually via control cables and together via control cables and switches

Description

The measuring amplifier GSV-1A4 is a measuring amplifier with 4 independent channels for sensors with strain gauges such as force sensors, torque sensors, acceleration sensors or extension sensors.

This measuring amplifier is also suitable for connecting strain gauge full and half bridges from 87.5 ohm to 5000 ohm and strain gauge quarter bridges with 350 ohm.

The measuring amplifier GSV-1A4 is supplied with a plug-in 18V power supply and SUB-D mating plugs.

The voltage and current outputs are at the 15-pin Sub-D socket and one ground for each analogue output. Both outputs have been calibrated and can be used at the same time.

The sensor inputs, bridge completions and the inputs for automatic zero adjustment of the individual channels are at the 37-pin Sub-D socket.

The bridge completion resistance with 0.1% tolerance for 350 ohm strain gauge is maintained. The quarter or half bridge mode can be set by the customer at the 37-pin Sub-D socket (see wiring diagram for 37-pin Sub-D socket).

As an option, it is possible to use the 6-wire technology of GSV-1L. The use of 6-wire technology must be configured to the circuit board.

GSV-1A4 M12 socket variant

The GSV-1A4 is optionally equipped with round connectors for the sensor connection.

The mating plugs must be ordered separately or are a component of the sensor.

Dimensions

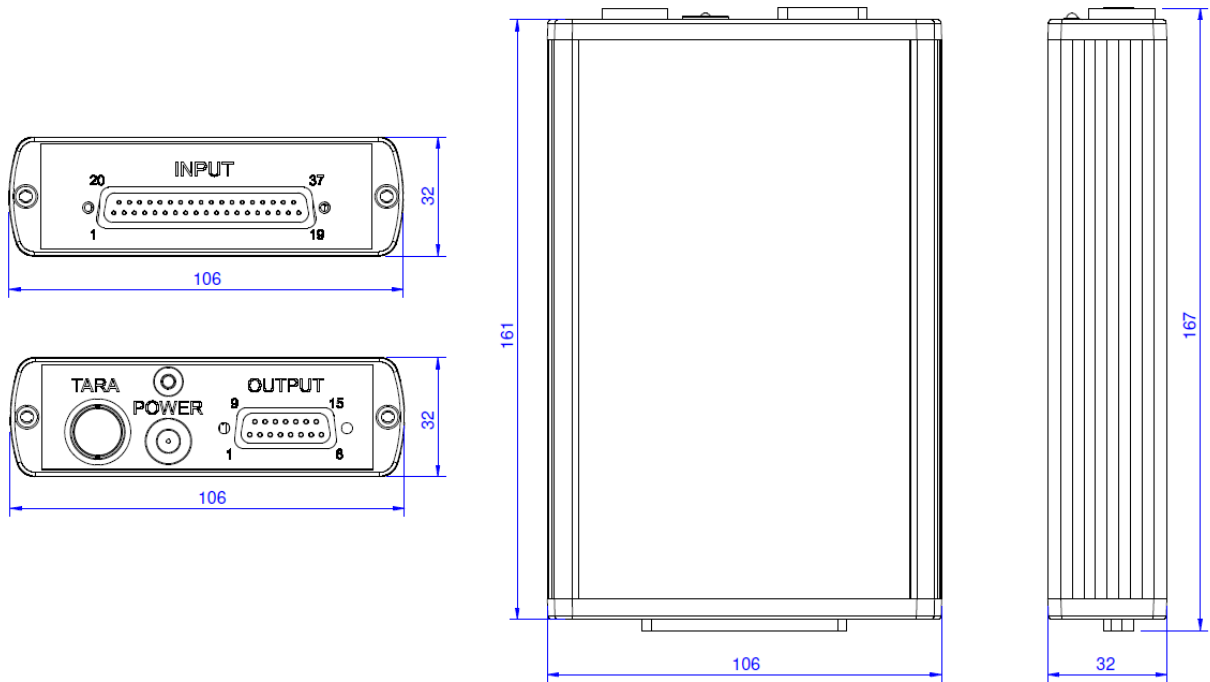

Technical Data

Input analog

Input sensitivity-steps	0.5 1.0 2.0	mV/V
Input resistance strain-gauge-full-bridge	87 ... 5000	Ohm

Output analog

Voltage output f	-10 ... 10	V
Output resistance - voltage	35	Ohm
Current output f	4 ... 20	mA
Output resistance - current	35	Ohm

Measuring frequency

Limit frequency (analog)	2.5	kHz
--------------------------	-----	-----

Supply

Supply voltage f	11 ... 30	V
Strain gauge bridge supply	5	V

Interface

Type of the interface	Analogue
-----------------------	----------

Zero adjustment

Type	Button
Tolerance	5 mV
Time period	90 ms
Debouncing time	4 ms
Trigger level f	3.5 ... 30 V
Trigger edge	falling

Temperature

Rated temperature range f	-10 ... 65 °C
Operating temperature range f	-40 ... 85 °C
Environmental protection	IP40

Basis Data

Housing	Aluminium
Connection	Connector
Connection type	SubD37/2
Number of channels	4-Kanal

Precision

Accuracy class	0,1%
Relative linearity error	0.02 %FS
Temperature effect on the zero point	0.2 %FS/10°C



Mounting

Wiring diagram for output socket 15-pin Sub-D socket

Description	Channel 1 Color/PIN	Channel 2 Color/PIN	Channel 3 Color/PIN	Channel 4 Color/PIN
Output voltage	brown 2	yellow 5	red-white 15	light green 12
Output current	red 3	dark green 6	brown-white 14	pink 11
Ground	orange 4	blue 7	black-white 13	white 10

Automatic Zero-adjustment is operated via push button or via digital input. Advice: the GNDio PIN 1 for digital input with PIN 8 is isolated from analog Ground PIN4.

Analog grounds PIN4, PIN7, PIN13, PIN10 are connected.

Connect GNDio (PIN1) permanently with Ground (PIN4) and connect Supply Voltage (PIN9) via Relais or button with PIN8 for remote-controlled zero adjustment.

GNDio for digital input	black 1
Zero-adjustment input	purple 8
Supply Voltage output	grey 9

The colors correspond to the core colors of the supplied 3 m cable with 15-pin connector SubD15.

Terminal assignment 37 pin Sub D, female

Symbol	Description	Channel 1	Channel 2	Channel 3	Channel 4
+U _S	positive sensor power supply	20	2	11	29
+U _F	positive sensor input	21	3	12	30
+U _D	positive differential input	22	4	13	31
QB350	quarter bridge completion 350Ω *	23	5	14	32
HB	half bridge completion **	24	6	15	33
-U _D	negative differential input **	25	7	16	34
-U _F	negative sensor input	26	8	17	35
-U _S	negative sensor power supply	27	9	18	36
Tara	automatic zero-point adjustment	28	10	19	37
GND	Grund/Schirm 1				

* Half bridge completion must be activated at the same time.

** The negative differential input (25, 7,16, 34) must be connected to the corresponding half bridge completion (24, 6,15, 33).

Wiring diagram of a full bridge to SubD-37, channel 1-4

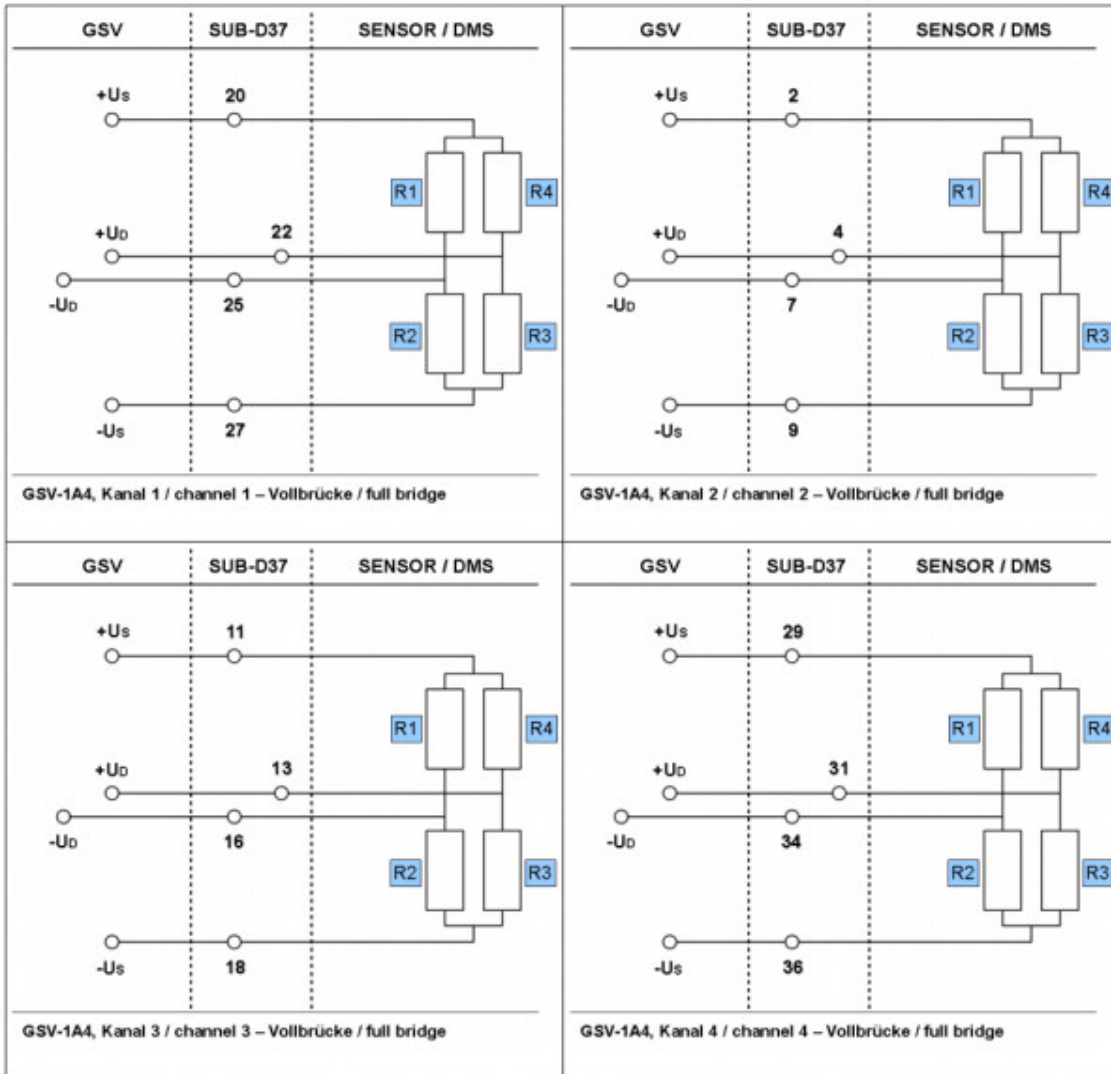

Wiring diagram of a half bridge to SubD-37, channel 1-4

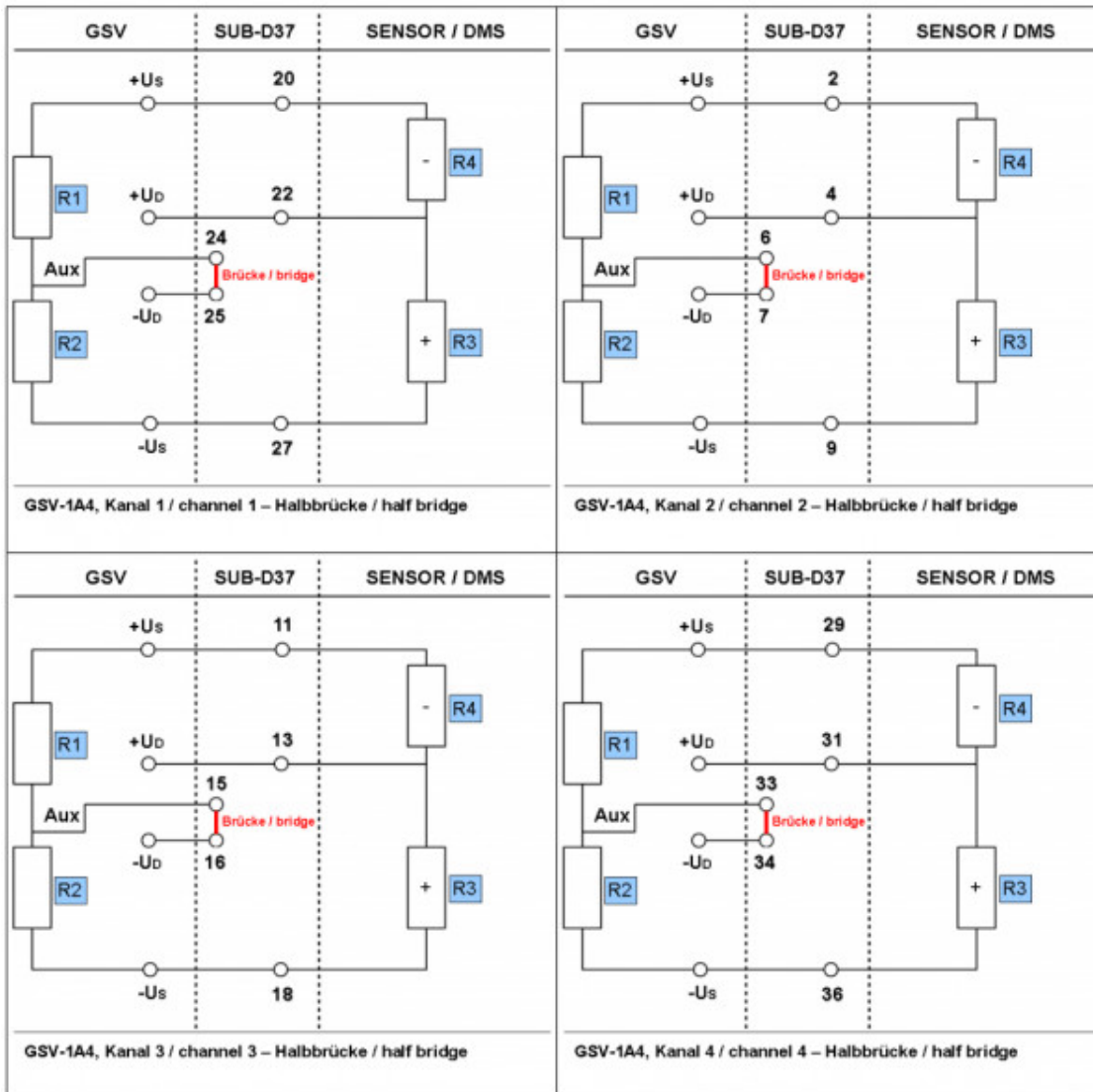

Wiring diagram of a quarter bridge to SubD-37, channel 1-4

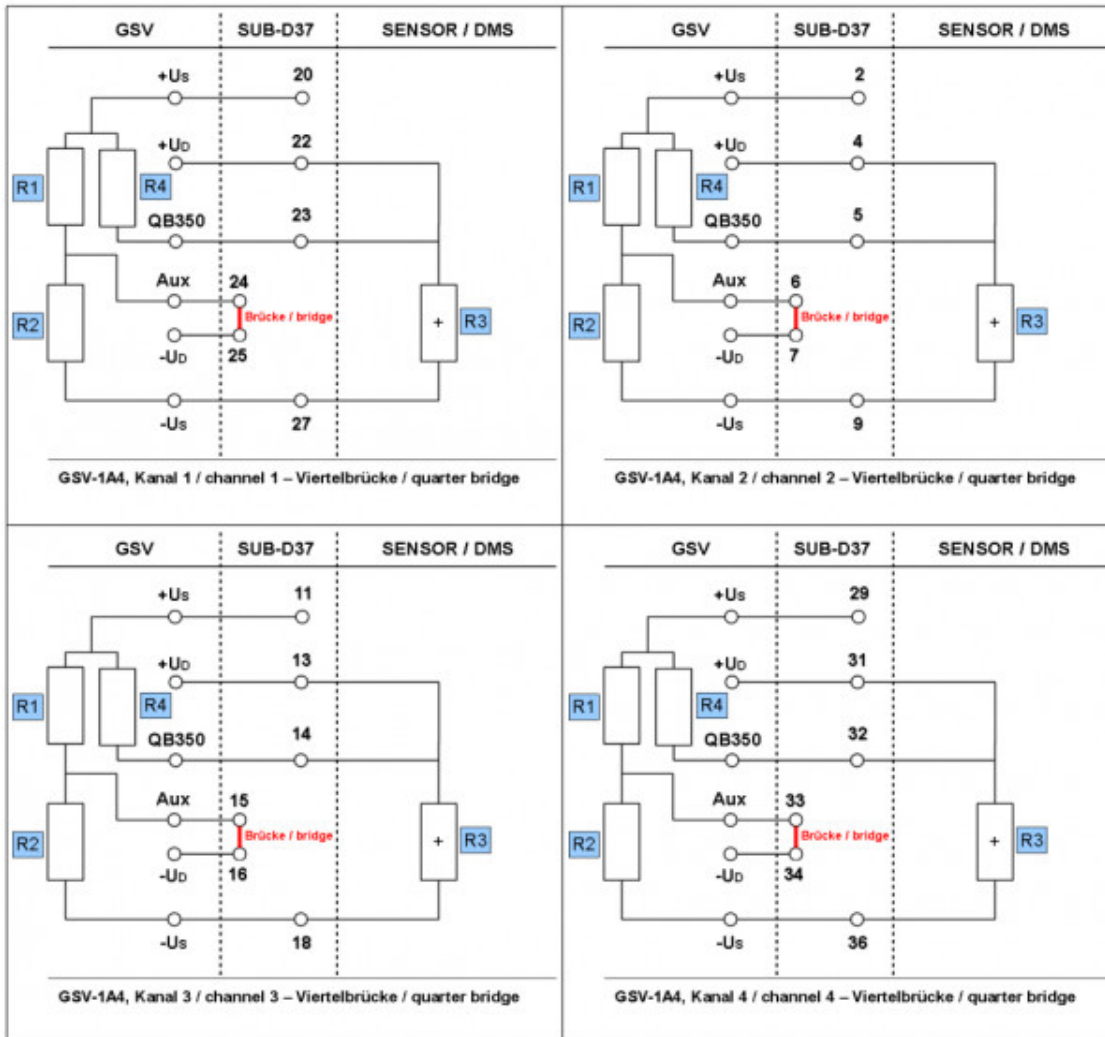

Adjusting the sensitivity

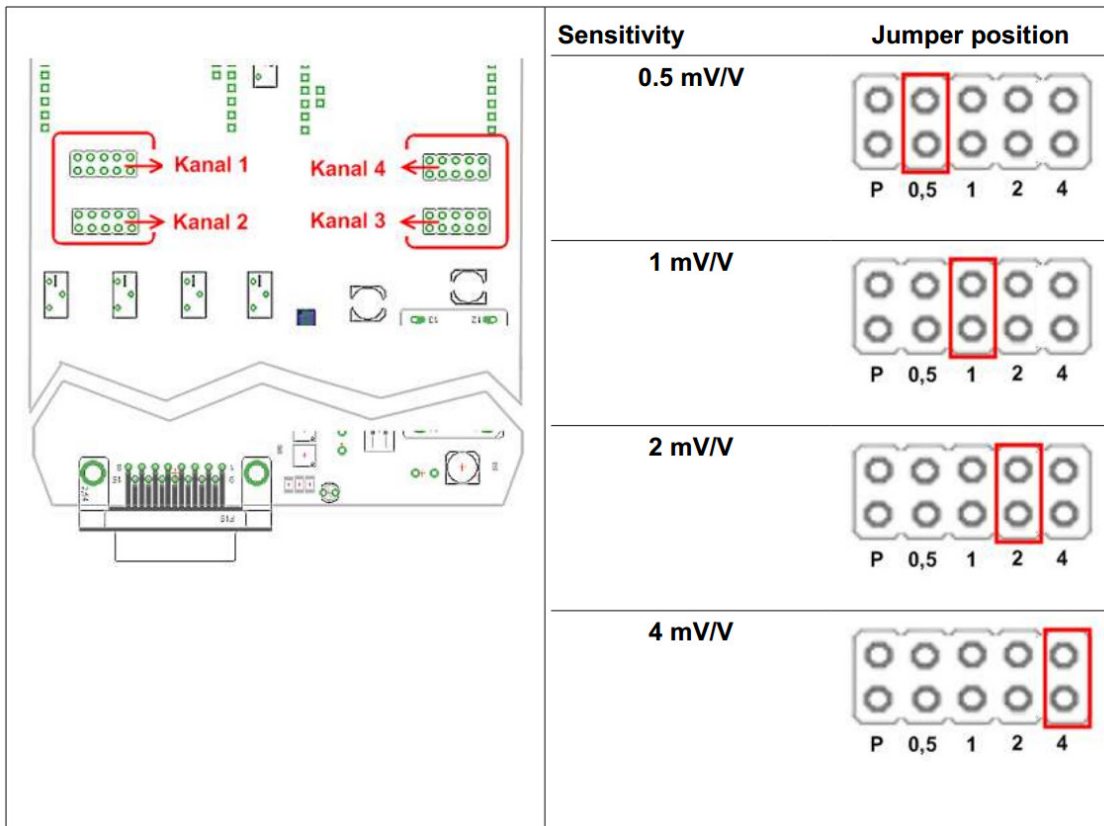

The sensitivity of channels 1 to 4 can be adjusted. On the circuit board of the GSV-1A4, each channel has a jumper post field with 4 plug options in total.



Opening the device

1. All 4 screw covers and the fastening screws on each end cover should be removed.
2. The cover with the (37-pin Sub-D socket) must be loosened using the two hexagonal bolts.
3. The circuit board is unplugged from the side of the 15-pin Sub-D socket.
4. In the M12 socket version, the cover is pushed through the housing slightly slanted.

accessories

Description	Description
 Configuration SubD37/m	Assembling the connector to sensor cable; Connector Type SubD, 37 pin, male (male), with hood
 Connector 15p/m/D-Sub/3,0m	Connector for the analog output of the measuring amplifier GSV-1A4
 Mounting-FEET-100	Mounting plates for GSV-3USB / GSV-3USBx2 / GSV-1A4 / GSV-4USB