

## K6D130 15kN/1.2kNm/M16



### Description

The multi-component sensor K6D130 allows force and torque measurement in three mutually perpendicular axes.

The multi-component sensor K6D130 is characterized by a big measuring range for torques at the same time with the small outer diameter.

With this multi-component sensor of the „second generation“ is used rod construction, which absorbs forces and torques directly on the pitch circle of the fastening thread.

The force transmission is applied on the 1 mm raised segments. The inner diameter of segments is used for the centering. Due to segmented, ring-shaped front surface, the optimal force transmission and therefore the best possible reproducibility in the range of about 0,1 % will be obtained.

The multi-component force sensor is very well suited for use in robotics, e.g.

- For collision detection
- "Teach-In"
- Collision detection
- Force or torque-controlled operation
- Load measurement in medicine, prosthetics, orthopaedic engineering
- Measurement in sports medicine
- Comfort / ergonomics measurements

The force and torque loadings are evaluated e.g. using a GSV-8DS measurement amplifier.

The sensor K6D130 4kN/250Nm is made of aluminium alloy, the sensor K6D130 10kN/750Nm is made of high-strength stainless steel 1.4542.

Dimensions

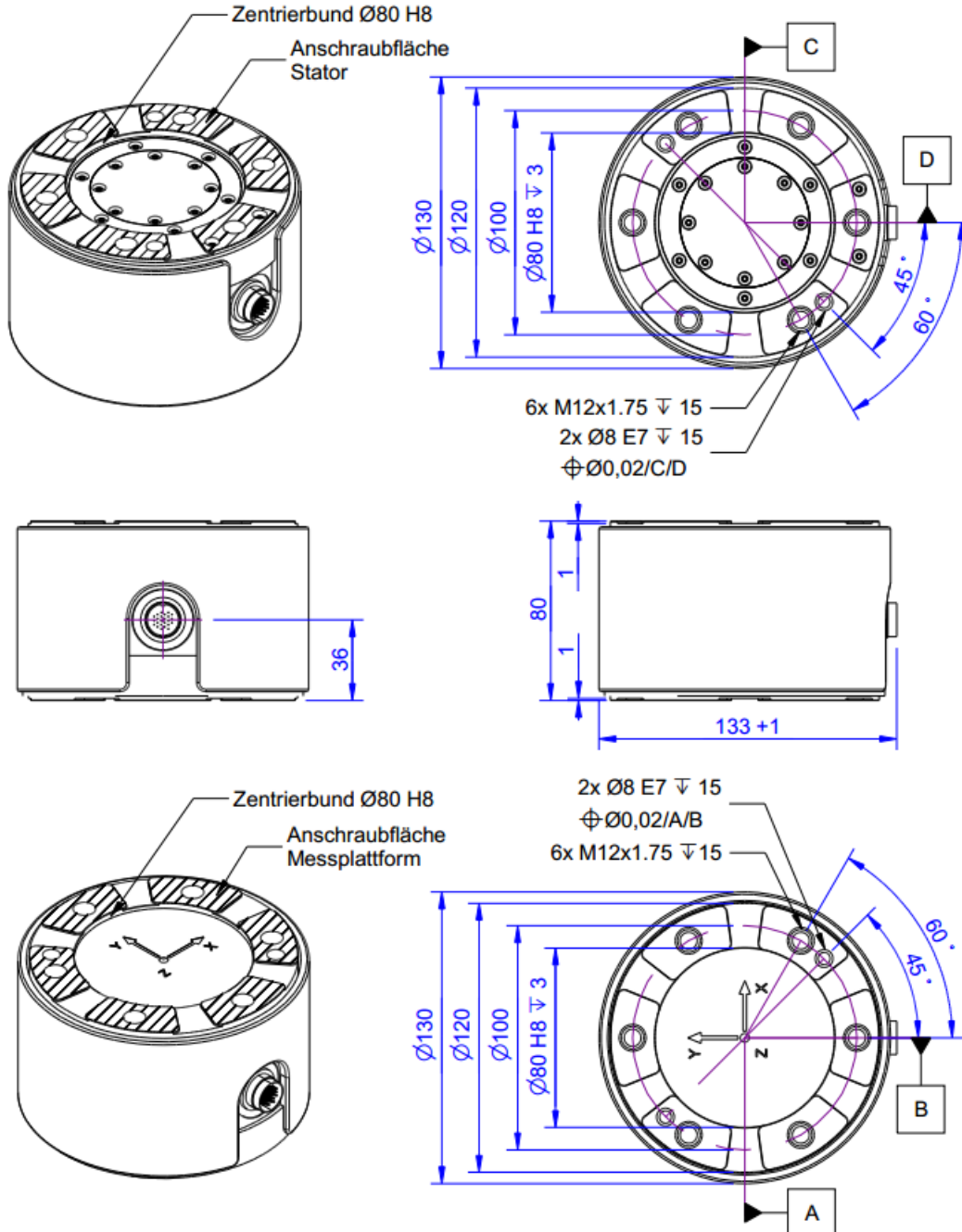

## Technical Data

### Force sensor

Type	6-Axis force sensor
Force direction	Tension / Compression
Rated force Fx	15 kN
Rated force Fy	15 kN
Rated force Fz	50 kN
Force introduction	Inner thread
Dimension 1	6x M12x1,75
Sensor Fastening	Inner thread
Dimension 2	6x M12x1,75
Operating force	300 %FS
Material	Stainless steel
Natural frequency	2.5 kHz
Dimensions	Ø130 x 80 mm
Height	80 mm
Length or Diameter	130 mm
Rated torque Mx	1.2 kNm
Rated torque My	1.2 kNm
Rated torque Mz	1.2 kNm
Torque limit	300 %FS
Bending moment limit	200 %FS

### Electrical Data

Input resistance	350 Ohm
Tolerance input resistance	10 Ohm
Output resistance	350 Ohm
Tolerance output resistance	10 Ohm
Insulation resistance	2 GOhm
Rated range of excitation voltage f	2.5 ... 5 V
Operating range of excitation voltage f	1 ... 5 V
Zero signal to	-0.05 mV/V
Zero signal from	0.05 mV/V
characteristic value range min	0.4 mV/V
characteristic value range max	0.9 mV/V

### Precision

Accuracy class	0,2%
Relative linearity error	0.1 %FS
Relative zero signal hysteresis	0.1 %FS
Temperature effect on zero signal	0.1 %FS/K
Temperature effect on characteristic value	0.01 %RD/K
Relative creep	0.1 %FS
Relative repeatability error	0.5 %FS

### Connection Data



Connection type	24 conductor open
Name of the connection	round plug connector M16, 24-pole, male

#### Eccentricity and Crosstalk

Crosstalk	1 %FS
-----------	-------

#### Temperature

Rated temperature range f	-10 ... 70 °C
Operating temperature range f	-10 ... 85 °C
Storage temperature range f	-10 ... 85 °C
Environmental protection	IP65

Abbreviation : RD: „Reading“; FS: „Full Scale“;

The application of a calibration matrix is required for the determination of the forces  $F_x$ ,  $F_y$ ,  $F_z$  and moments  $M_x$ ,  $M_y$ , and  $M_z$  from the 6 measurement channels, and to compensate for the crosstalk.

The calibration data are individually determined and documented for the sensor.

The measurement error is expressed individually by the specification of the extended measurement uncertainty ( $k = 2$ ) for the forces  $F_x$ ,  $F_y$ ,  $F_z$ , and moments  $M_x$ ,  $M_y$ ,  $M_z$ .

## Pin Configuration

Channel	Symbol	Description	Wire colour	PIN
1	+Us	positive bridge supply	white	1
	-Us	negative bridge supply	brown	2
	+Ud	positive bridge output	green	3
	-Ud	negative bridge output	yellow	4
2	+Us	positive bridge supply	gray	5
	-Us	negative bridge supply	pink	6
	+Ud	positive bridge output	blue	7
	-Ud	negative bridge output	red	8
3	+Us	positive bridge supply	black	9
	-Us	negative bridge supply	purple	10
	+Ud	positive bridge output	gray-pink	11
	-Ud	negative bridge output	red-blue	12
4	+Us	positive bridge supply	white-green	13
	-Us	negative bridge supply	brown-green	14
	+Ud	positive bridge output	white-yellow	15
	-Ud	negative bridge output	yellow-brown	16
5	+Us	positive bridge supply	white-gray	17
	-Us	negative bridge supply	gray-brown	18
	+Ud	positive bridge output	white-pink	19
	-Ud	negative bridge output	pink-brown	20
6	+Us	positive bridge supply	white-blue	21
	-Us	negative bridge supply	brown-blue	22
	+Ud	positive bridge output	white-red	23
	-Ud	negative bridge output	brown-red	24

*Shield: connected with sensor housing;*

## Manual

### Stiffness Matrix K6D130 15kN/1.2kNm

256.9 kN/mm	0.0	0.0	0.0	10275 kN	0.0	$u_x$
0.0	256.9 kN/mm	0.0	-10275 kN	0.0	0.0	$u_y$
0.0	0.0	1062.7 kN/mm	0.0	0.0	0.0	$u_z$
0.0	-10275 kN	0.0	1384.2 kNm	0.0	0.0	$\phi_x$
10275 kN	0.0	0.0	0.0	1384.2 kNm	0.0	$\phi_y$
0.0	0.0	0.0	0.0	0.0	941.0 kNm	$\phi_z$









Element	Beschreibung des Zusammenhangs
[kN/mm]	Kraft - Weg
[kNm]	Drehmoment - Verdrillung
[kN]	Kraft - Verdrillung und Drehmoment - Weg

## Mounting

The forces is applied to an annulus ( $\emptyset 120$ - $\emptyset 80$ ) on the end faces of the sensor. No force is applied to the area inside the ring.

A centring hole is provided to secure the angular position.

accessories

Description	Description
	K6D-CalibrationMatrix SL Standard calibration matrix "Small load" for the sensors with small measuring ranges
	K6D-CalibrationMatrix SL/Plus High accuracy calibration matrix for 6-axis force/torque sensors;
	GSV-8AS 8-channel amplifier with USB port, analog output, 16x DIO, UART interface.
	GSV-8DS 8-channel amplifier with USB port, analog output, UART interface. Other versions GSV-8AS CAN with Canbus and GSV-8AS EC with EtherCAT fieldbus.
	K6D130-Adapter Set Adapter plate set for mounting on K6D130 and on robotics flange;
	K6D-Adapter Development Indicative offer for an adapter set, Consisting of e.g. 2 plates, For mounting a device / flange on K6D sensor;
	Connection cable M16/24p/f-m16/24p/m Connection cable for K6D sensor to 8-channel measuring amplifier GSV-8AS;
	Connection cable M16/24p/f-SubD44HD/m Connection cable for K6D sensor to 8-channel measuring amplifier GSV-8DS D-Sub44HD;